

Fixed Short V Head Pipe Stand



FEATURES AND BENEFITS

- V Head for pipe up to 12" in diameter
- 2500 lb. (1135 kg.) load capacity
- Height adjustment range of 20" to 37"
- Designed for low-clearance applications
- ACME threaded adjustment rod for smooth height changes
- Locking ring allows fast, secure height adjustments
- Rigid steel frame ideal for shop and stationary use
- Fixed leg design provides maximum stability



Model 455-FXS

OVERVIEW

Sawyer's Fixed Short V Head Pipe Stand is built for low-clearance applications, featuring a compact 20"-37" working height and support for pipe up to 12". The heavy-duty steel frame includes reinforced legs, a secure V-head, and a smooth ACME adjustment rod with quick-lock washer for fast, reliable height adjustments.

DIMENSIONS

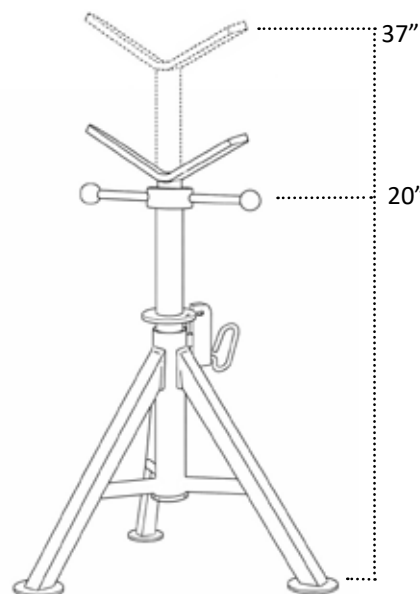

Model No.	Description
455-FXS	Fixed Short V Head Pipe Stand

Contact Sawyer Mfg. Company for more info on the Pipe Stand.

Follow us on social media and watch product videos on our YouTube channel **Sawyer Mfg**