

Rim Clamp Manual

Model: 258

About Us

We appreciate your business!

Congratulations on your new SAWYER product. We are proud to have you as our customer and will strive to provide you with the best service and reliability in the industry. This product is backed by our extensive warranty and world-wide service network. To locate your nearest distributor or service agency, please contact us at the phone number and address listed on the bottom of each page.

You are in good company!

Sawyer Manufacturing Company is the world leader in the design and manufacture of pipeline and welding equipment and has been since 1948. Sawyer equipment has become a standard in the industry and continues to set the benchmark for quality and durability.

This user operation manual has been made to instruct you for the best use and operation of your Sawyer product. Your satisfaction with our products is our main goal. Please read this entire manual carefully, noting all tips, notes and warnings. Safety always comes first.

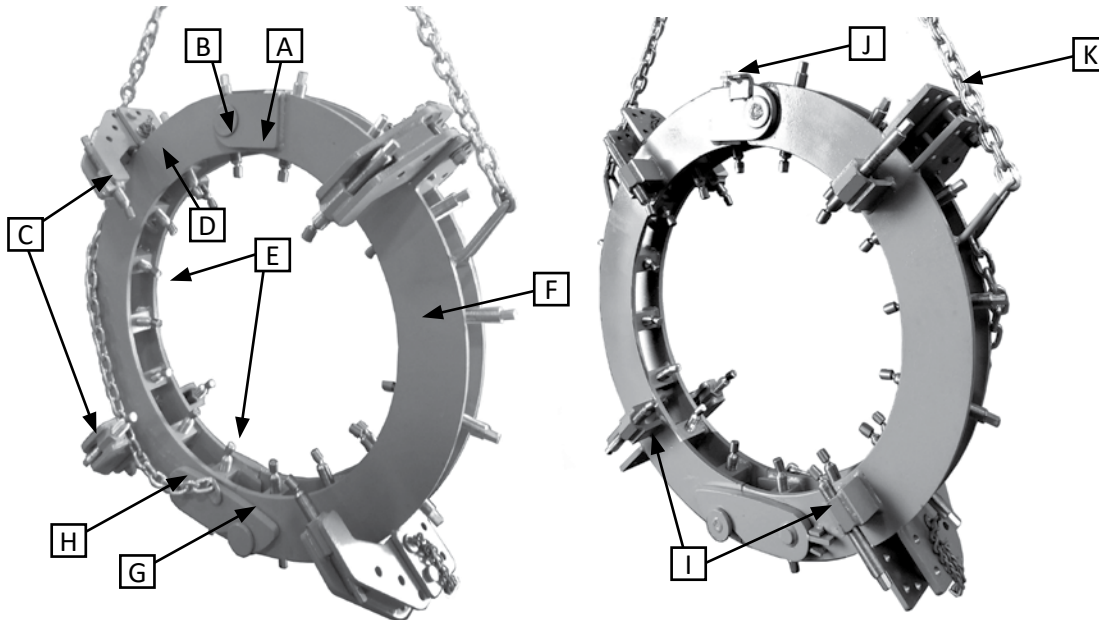

- A. Hingeplate
- B. Hinge Pin
- C. Adjustable Jackbar with Jackscrews
- D. Jackbar Latch Pin
- E. Reforming Jackscrews
- F. Main Frame
- G. Locking Hook
- H. Hook Release Chain
- I. Stable Jackbar with Jackscrews
- J. Level and Support Hook
- K. Lifting Chain

⚠

CAUTION

⚠

CAUTION: Sawyer Manufacturing offers a pair of easy to use Rim Clamps for the purpose of welding two pipes together. We recommend two or more people for the installation of the Rim Clamp. These clamps are not intended to be used as sole support of the pipe nor to lift the pipe. These clamps are designed to reform pipe only and for alignment of tees, elbows, valves or other forged fittings. After each use clean and store in a warm, dry area.

Record the following information for warranty purposes:

Where purchased: _____

Purchase date: _____

Equipment Serial #: _____

Warranty

All products manufactured by or for Sawyer Manufacturing Company are guaranteed against defects due to faulty workmanship or materials for twelve months from the date of purchase.

This guarantee is limited to the repair or replacement of any parts found to be defective, and no other liability—expressed, implied, or contingent—is assumed.

Operation

Tools Needed For Operation*

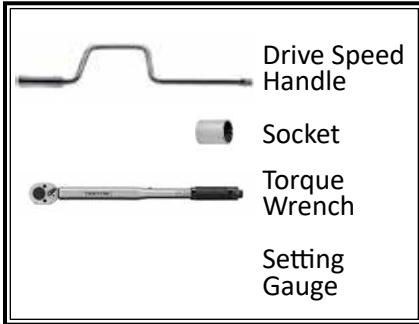

*Included

Rim Clamp Type	Pipe Tensile Strength		Maximum Recommended Wall Thickness According to Pipe Diameter					
	PSI	MPA	4" - 12" DIA	14" - 24" DIA	26" - 30" DIA	32" - 48" DIA	50" - 60" DIA	62" - 72" DIA
STD	45,000	310	1/2"	3/4"	7/8"	1"	1 1/8"	1 1/4"
ULTRA	45,000	310	1/2"	3/4"	1"	1 1/8"	1 1/4"	1 3/8"
	65,000	448	7/16"	5/8"	3/4"	1"	1 1/8"	1 3/8"
	70,000	483	3/8"	1/2"	3/4"	7/8"	1"	1 1/4"
	80,000	552	3/8"	1/2"	5/8"	3/4"	1"	1 1/8"
Pipe Wall Thickness								

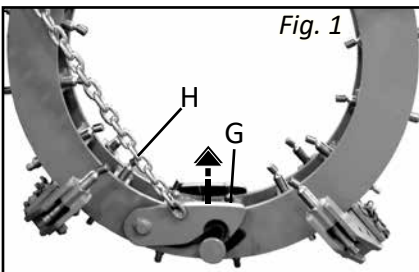

1. Unlatch the Locking Hook (G) by pulling on the Hook Release Chain (H, Fig. 1)

Tip: Lightly rest clamp on flat surface to release pressure before unlatching

Note: 4" - 12" clamps may be placed over pipe manually. Larger clamps must be placed by a lifting device using the lifting chain.

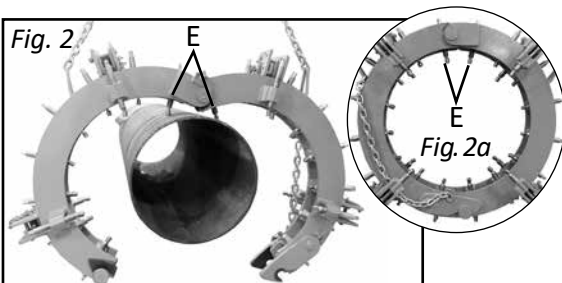

2. To center clamp on the pipe (Fig. 2) loosen all Reforming Jackscrews (E) except the top 2 (Fig. 2a) before placing on the pipe.

Tip: Use the setting gauge to preset the top 2 Reforming Jackscrews before placing on the pipe

Note: If not loosened, the weight of the clamp may damage jackscrews

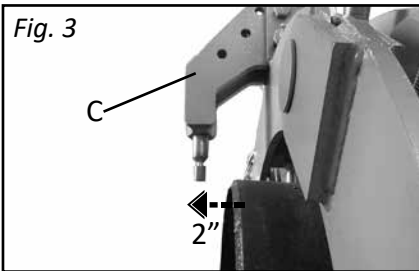

3. Lower clamp onto pipe so that Adjustable Jackbars (C) extend approximately 2" beyond the end of the pipe. (Fig. 3) As the clamp starts to close around the pipe, the Locking Hook will automatically latch.

Note: If Locking Hook doesn't automatically latch, the operator will need to push the two sides together until it latches

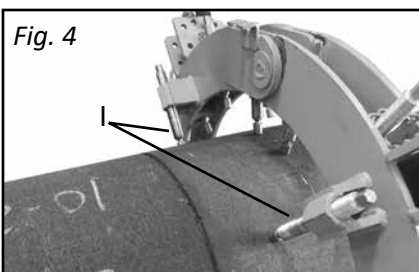

4. Center the clamp on the pipe using the Reforming Jackscrews (E) to +/- 1". Adjust Jackscrews on the Stable Jackbars (I, Fig. 4) so that clamp is perpendicular to the pipe.

Note: Slight adjustments may be needed to Reforming Jackscrews (E).

Operation

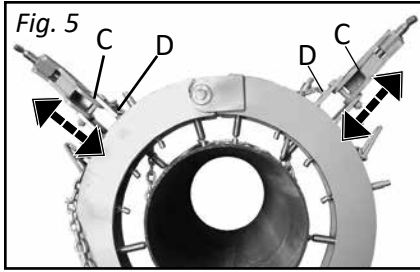

5. To align secondary pipe/fitting (Fig 5), top Adjustable Jackbars (C) may be lifted up by removing the Jackbar Latch Pin (D) and rotating them out of the way.

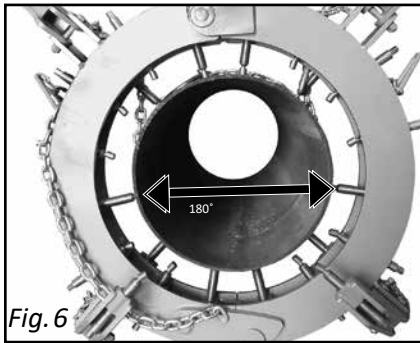

6. When pipe joints are aligned, the Reforming Jackscrews (E) can be tightened to reform the pipe.

Tip: Only tighten Reforming Jackscrews on high spots, it is not necessary to tighten all Reforming Jackscrews

Note: It is not necessary to use all of the Reforming Jackscrews (E), only those that are over high spots and those located 180° (Fig. 6) from the high spot. It will be necessary to reduce the pressure of some Jackscrews as you tighten others. It may be necessary to repeat this procedure several times.

Tip: A small amount of pressure is all that is needed when Reforming Jackscrews are used on the high spots