



Hydraulic Dent Remover Manual

Model 224

About Us

We appreciate your business!

Congratulations on your new SAWYER product. We are proud to have you as our customer and will strive to provide you with the best service and reliability in the industry. This product is backed by our extensive warranty and world-wide service network. To locate your nearest distributor or service agency, please contact us at the phone number and address listed on the bottom of each page.

You are in good company!

Sawyer Manufacturing Company is the world leader in the design and manufacture of pipeline and welding equipment since 1948. Sawyer equipment has become a standard in the industry and continues to set the benchmark for quality and durability.

This user operation manual has been made to instruct you for the best use and operation of your Sawyer product. Your satisfaction with our products is our main goal. Please read this entire manual carefully noting all tips, notes and warnings. Safety always comes first.

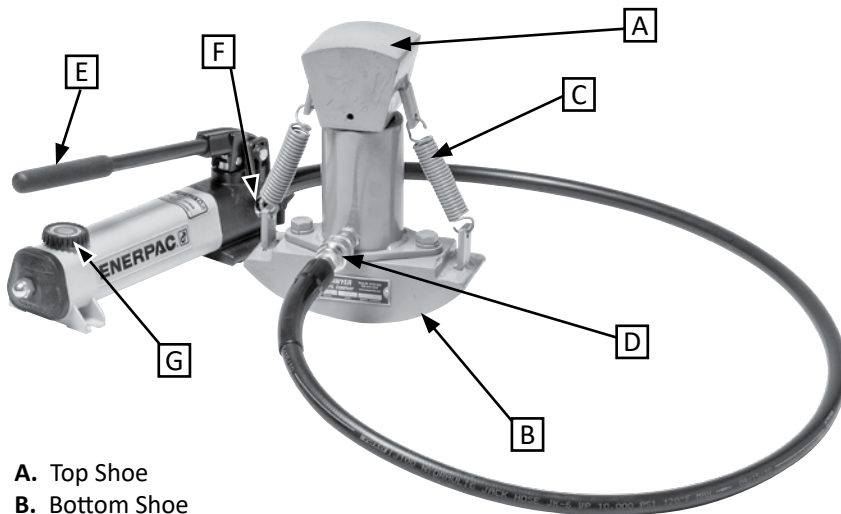

- A. Top Shoe
- B. Bottom Shoe
- C. Spring
- D. 1/2" Hydraulic Coupling
- E. Hydraulic Handle
- F. Hydraulic Release Valve
- G. Hydraulic Fluid Reservoir

| | | |
|--|---------|--|
| | CAUTION | |
| <p>CAUTION: Sawyer Manufacturing Company offers a precision manufactured Hydraulic Pipe Reformer built for strength and durability. The buildup of high pressure inside the Hydraulic Pipe Reformer can cause injury to personnel and damage to equipment. To avoid discharge of the pushing ram from the Hydraulic Pipe Reformer, ensure that appropriately sized equipment is used. To avoid a rapid discharge of hydraulic pressure ensure that all pressure hoses are connected and secure. When the hydraulic pressure does not increase enough to reform the pipe, check the hydraulic fluid levels and add hydraulic fluid as necessary.</p> | | |

| |
|--|
| <p>Record the following information for warrant purposes:</p> <p>Publication date: March 17, 2013</p> <p>Where purchased: _____</p> <p>Purchase date: _____</p> <p>Equipment Serial #: _____</p> |
|--|

| |
|--|
| <p>Warranty</p> <p>All products manufactured by or for Sawyer Manufacturing Company are guaranteed against defects due to faulty workmanship or materials for twelve months from the date of purchase.</p> <p>This guarantee is limited to the repair or replacement of any parts found to be defective, and no other liability, expressed, implied or contingent is assumed.</p> |
|--|

Installation

Tools Needed For Operation*

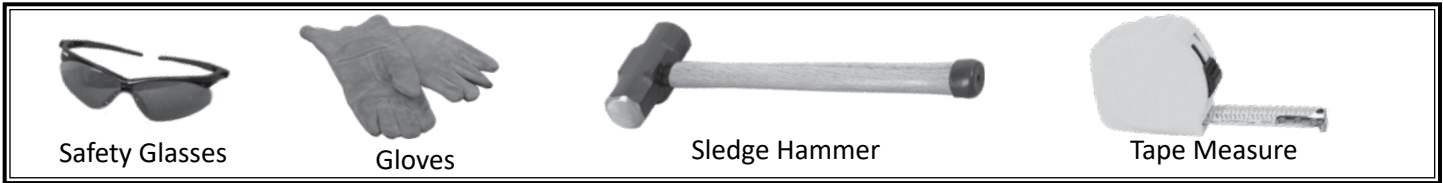

*Not Included



Installation

1. Connect the Hydraulic Dent Remover to the Enerpac Hose (Fig. 1)

Figure 2. Out-of-Round Pipe Diagram

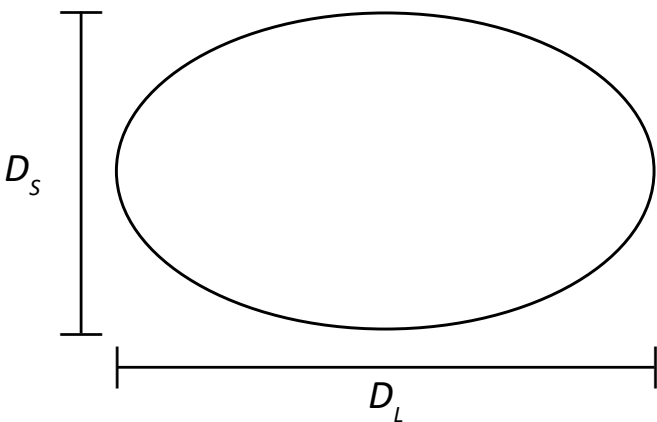

D_L = Long Diameter
 D_S = Short Diameter
 D = Nominal Diameter

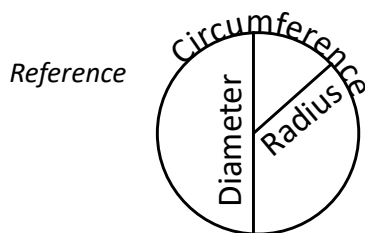

Preparation

1. Determine the percent out-of-round by measuring the Short and Long Diameter of the out of round pipe.

Use the following equation to determine the percent out-of-round:

$$\% \text{ Out of Round} = \frac{D_L - D_S}{D} \times 100\%$$

Note: It was established during testing that increasing the Short Diameter of the pipe with the Hydraulic Pipe to the original Long Diameter of the pipe will result in the lowest percent out-of-round.

Operation

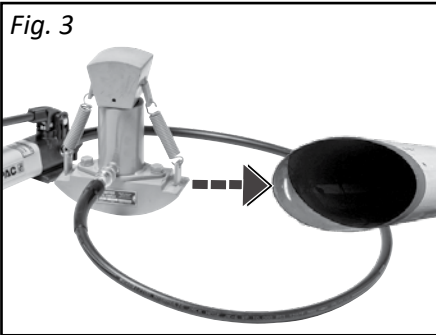

1. Insert the Hydraulic Dent Remover so that the head and base of the Hydraulic Dent Remover are in line with the Short Diameter of the pipe. (Fig. 3)

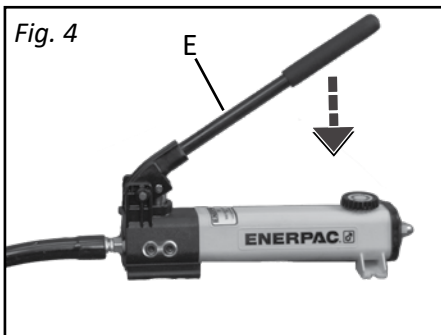

2. Use the hand pump (E) to increase the hydraulic pressure. (Fig. 4)

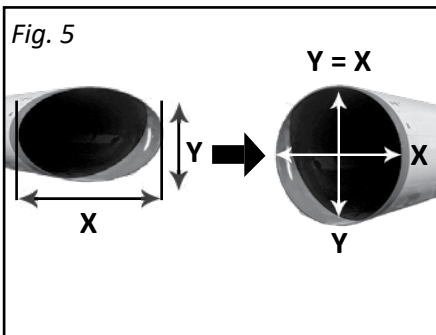

3. Increase the pressure on the Hydraulic Dent Remover until the Short Diameter of the pipe (Y, Fig. 5) measures the original Long Diameter of the pipe. (X, Fig. 5)

Note: The diameter of the pipe in line with the Hydraulic Dent Remover will decrease to approximately the Nominal Diameter.

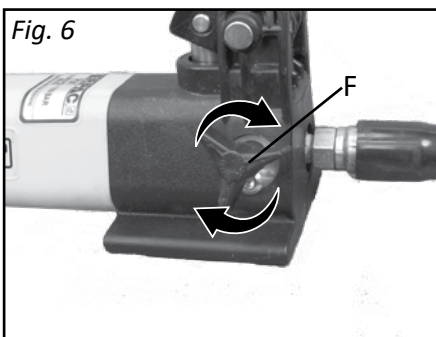

4. Relieve the pressure on the Hydraulic Dent Remover and lower the head of the reformer. (Fig. 6)

Note: Measure the diameter of the pipe and ensure that the pipe meets out-of-round criteria for any couplings or pipe fittings, if not repeat steps 1 through 4 of the operation procedure.