

Mega Jack Pipe Stand



Model 456

OVERVIEW

Sawyer's Mega Jack Pipe Stand is ideal for rolling and positioning large diameter pipe up to 36". Roller head wheels safely rotate pipe quickly and efficiently while reducing pipe travel on a 2,500 lb. load capacity.

FEATURES AND BENEFITS

- 11.5" V Head with rollers for pipe up to 36" in diameter
- 2,500 lb. load capacity with roller head wheels and casters
- 5,000 lb. load capacity without roller head wheels and casters
- Height adjustment range of:
 - 24" to 36" with jack only
 - 32" to 44" with casters
- Large, easy-to-turn, adjustment screw
- Suitable for large pipe support applications
- 5 leg construction for stability
- Locking casters for easy positioning

DIMENSIONS

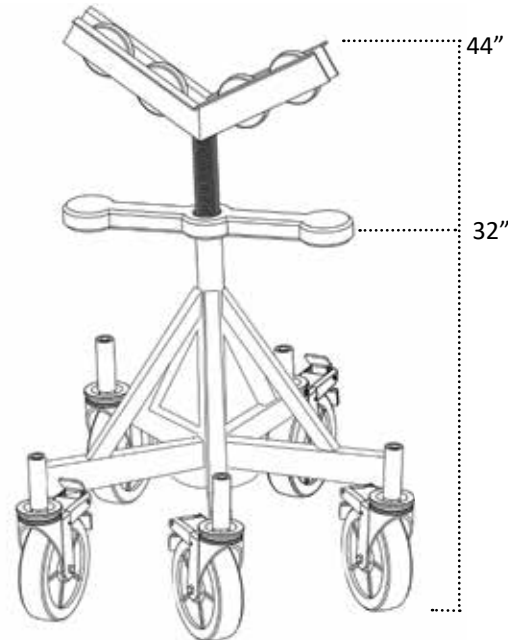

ESTIMATED SHIPPING WEIGHT

Model No.	Description	Weight
456	Mega Jack Pipe Stand	115 lbs. 52.16 kg.